



開合精密工業股份有限公司



European Community

專業精密夾具系統

CNC Professional Chucks

臺灣製造

Made In Taiwan



CH系列 中空精密動力夾頭系列



High Precision Thru-Hole Chuck Series



特色 / Product Features

1. 採用高級合金鋼，且重要零件皆經硬化處理，加強結構剛性，提昇穩定之精度與使用壽命。
2. 採中空大孔徑貫通設計，方便長形棒材類加工，並可搭配使用自動化設備，提高產能。
3. 搭配迴轉油壓缸，提供穩定壓力夾持工件，可適用於廣泛加工條件。

1. Adopt high-grade alloy steel, the key parts have been hardening treatment to strengthen structural rigidity, upgrading the accuracy and durability.
2. Large caliber thru-hole design, allowing the bar material go through, furthermore, it can be complemented to automatic processing equipment for enhancing the machining efficiency.
3. Complement the rotary hydraulic cylinder to provide a stable pressure chucking workpiece.

使用示意圖 / Application Illustration

高速中空液壓迴轉缸

High Speed Thru Hole Rotary Hydraulic Cylinder

高速中空三爪液壓精密動力夾頭

3-Jaw High Speed Hollow Power Chucks

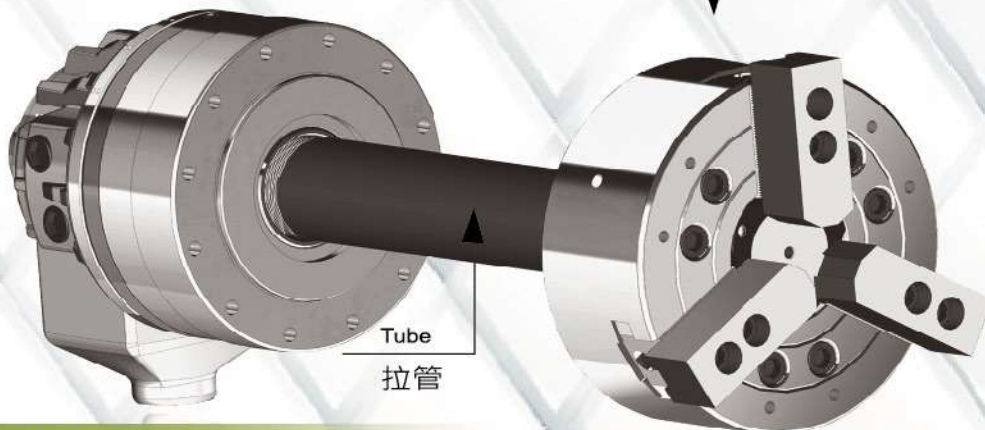

產品介紹 / Production Introduction

在目前製造工業上「品質」與「效能」並重已成趨勢時，「量產自動化」與「品質穩定性」已變為不可或缺的生產品條件。基於上列需求，**AUTO CLAWS** 致力於製造高速中空型液壓精密夾頭系列，在堅持嚴謹的生產品流程與重視品質管理制度下製造產品，以確保製造出的每一批量、每一項產品都能符合高精度高品質之要求；且搭配使用 **AUTO CLAWS** 高品質精密中空迴轉液壓缸，並落實 **AUTO CLAWS** 建議使用方法，相信必能滿足客戶的需求。

Quality and efficiency are becoming the trend in modern industry, automatic mass production and stable quality are the essential conditions. According to the above requirements, Autoclaws has been devoted to manufacture high-quality, high speed thru-hole power chuck series. We are persisting in producing our products by strict process control and quality inspection to ensure each batch, every product achieving the high precision and high quality requirements. Using the chucks go with Autoclaws' high-quality thru-hole rotary hydraulic cylinder as well as implements Autoclaws' suggested instruction specification, we believe that should be able to satisfy customer's requirements.

Adhere to the best quality and intentions of excellent service

3-Jaw

3 Jaw High Precision Thru-Hole Chuck Series

特色 / Product Features

- 1.適用於夾持圓形棒材物件切削加工。
 - 2.採用高級合金鋼，且重要零件皆經硬化處理，加強結構剛性，提昇穩定之精度與使用壽命。
 - 3.採中空大孔徑貫通設計，方便長形棒材類加工，並可搭配使用自動化設備，提高產能。
 - 4.搭配迴轉缸，提供穩定壓力夾持工件，可適用於廣泛加工條件。
 - 5.專業精密研磨使其具有高精度度、精密重複夾持精度、高夾持力。
- 1.Suitable for round-bar shape objects to clamp for cutting process.
 2.Using the advanced high-strength alloy steel, the key components have been treated with hardening which is strengthening the structure and enhancing the stability with accuracy and durability.
 3.Large caliber design allowing the bar material go through, furthermore, it can be complemented to automatic processing equipment for enhancing the machining efficiency.
 4.The chucks complement the rotary hydraulic cylinder to provide a stable pressure for various chucking conditions.

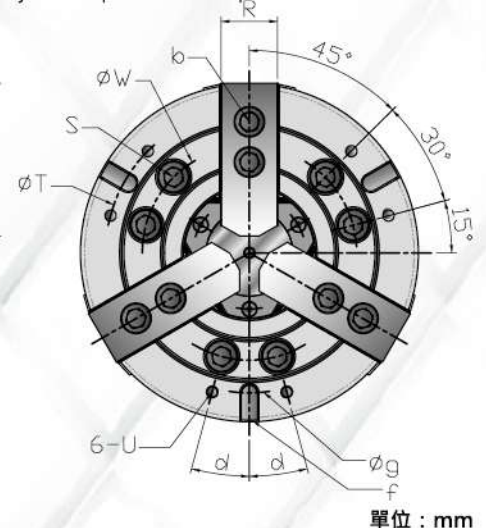
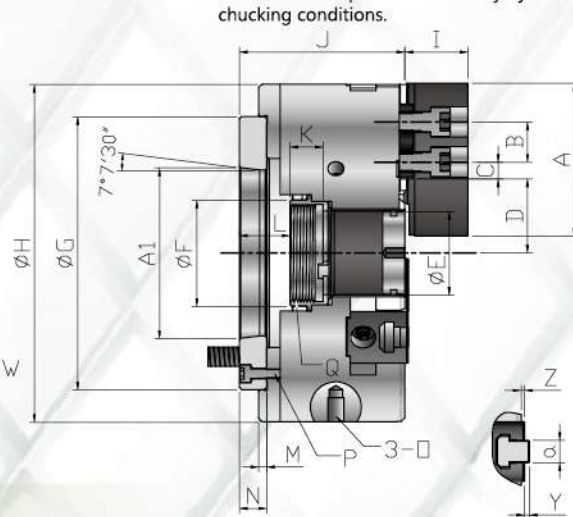
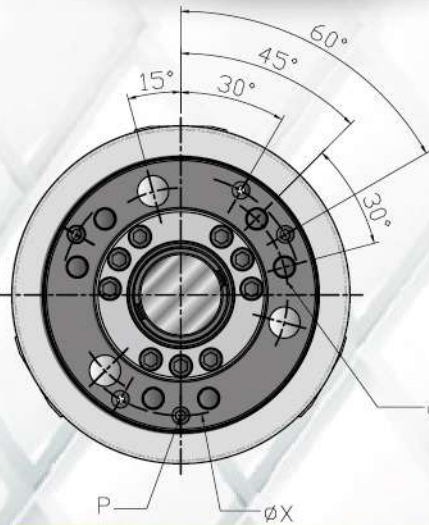

單位：mm

外觀尺寸 / Dimensions

型號 Model	尺寸 Dimension															
	A1	A	B	C (max)	C (min)	D (max)	D (min)	E	F	G	H	I	J	K	L (max)	L (min)
CH05-3JA4	63.5	54	14	21.3	6	25.92	23.61	33	45	110	135	26	71	20	16	6
CH06-3JA5	82.55	66	20	23.75	8.25	32.5	29.7	45	60	140	169	29	91	19	26	14
CH08-3JA6	106.36	95	25	30	10.5	38.7	35	52	66	170	210	39	103	20.5	31.5	15.5
CH10-3JA8	139.7	110	30	35	11	51	46.6	75	94	220	254	43	113	25	26.5	7.5

型號 Model	尺寸 Dimension																		
	M	N	O	P	Q	R	S	T	U	W	X	Y	Z	a	b	d	f	g	
CH05-3JA4	4	15		M6	M40XP1.5	23	3-M10X75L	118	M6	82.6	96	2	2	10	M8	12.5	8X17X4		
CH06-3JA5	5	15		M6	M55XP2.0	26	6-M10X95L	146	M8	104.8	116	3	2	12	M10	15	10X18X4	130	
CH08-3JA6	5	17	M10	M6	M60XP2.0	35	6-M12X110L	179	M8	133.4	150	3	2	14	M12	15	12X24X5	160	
CH10-3JA8	5	18	M10	M8	M85XP2.0	40	6-M16X120L	224.5	M10	171.4	190	3	2	16	M12	15	14X25X5	200	

技術資料 / Technical Data

型號 Model	主軸端尺寸 Spindle nose size	通孔直徑 Thru-Hole mm	夾持直徑範圍 Gripping range mm		活塞行程 Plunger Stroke mm	爪行程 (直徑) Jaw Stroke (diameter)	容許最大入力 Max Draw Bar Force kN (kgf)	最大靜止把握力 Max Gripping Force kN (kgf)	容許最高迴轉速度 Max Speed min ⁻¹ (r.p.m)	重量 (含標準軟爪) Net Weight with Soft top jaws kg	轉動慣量 Moment of inertia kg · m ²	最大壓力 Max pressure MPa(kgf/cm ²)	搭配硬爪 Matching Hard top jaw	搭配軟爪 Matching Soft top jaw	搭配迴轉油壓缸 Matching Cylinder
			Max.	Min.											
CH05-3JA4	A2-4	33	135	12	10	4.6	17.5(1784)	36(3671)	7000	6.7	0.018	註1 (Mark1)	HJ05	SJ05	RHC-10系列
CH06-3JA5	A2-5	45	169	16	12	5.5	22(2243)	57(5812)	6000	13.58	0.05		HJ06	SJ06	RHC-12系列、RHC-S13系列
CH08-3JA6	A2-6	52	210	13	16	7.4	34.8(3549)	86(8769)	5000	23.74	0.13		HJ08	SJ08	RHC-15系列、RHC-S14系列
CH10-3JA8	A2-8	75	254	31	19	8.8	43(4385)	111(11319)	4200	40	0.31		HJ10	SJ10	RHC-18系列、RHC-S17系列

註1：最大壓力 = (容許最大入力) ÷ (搭配迴轉油壓缸活塞拉力端面面積) / 註2：限用二硫化鋯作為潤滑用脂 / 註3：每8小時潤滑
 Remark 1: Maximum Pressure = (maximum input power) ÷ (Mating with the rotary cylinder's pulling side piston area)
 Remark 2: Using only MoS2 as lubricant.
 Remark 3: Lubricate per 8 hours



CH2J

二爪中空精密動力夾頭系列



2-Jaw

2 Jaw High Precision Thru-Hole Chuck Series

特色 / Product Features

- 1.適用於夾持不規則形狀物件切削加工。
 - 2.採用高級合金鋼，且重要零件皆經硬化處理，加強結構剛性，提昇穩定之精度與使用壽命。
 - 3.採中空大孔徑貫通設計，方便長形棒材類加工，並可搭配使用自動化設備，提高產能。
 - 4.搭配迴轉缸，提供穩定壓力夾持工件，可適用於廣泛加工條件。
 - 5.專業精密研磨使其具有高精度、精密重複夾持精度、高夾持力。
- 1.Suitable for irregular shape objects to clamp for cutting process.
 - 2.Using the advanced high-strength alloy steel, the key components have been treated with hardening which is strengthening the structure and enhancing the stability with accuracy and durability.
 - 3.Large caliber design allowing the bar material go through, furthermore, it can be complemented to automatic processing equipment for enhancing the machining efficiency.
 - 4.The chucks complement the rotary hydraulic cylinder to provide a stable pressure for various chucking conditions.

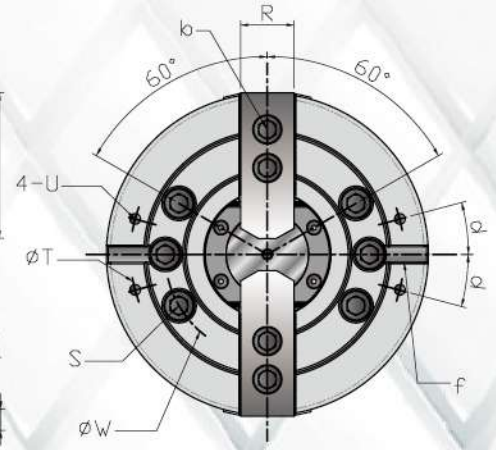
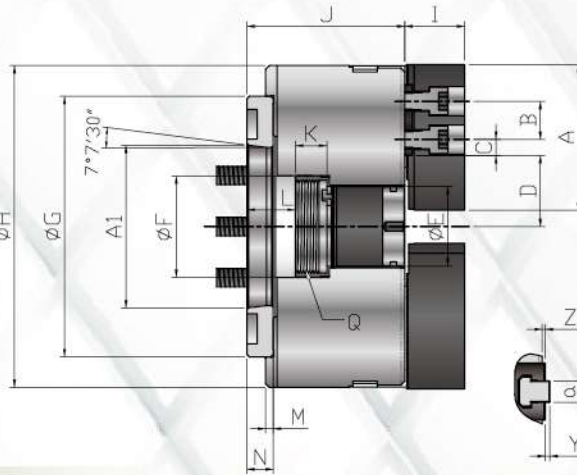
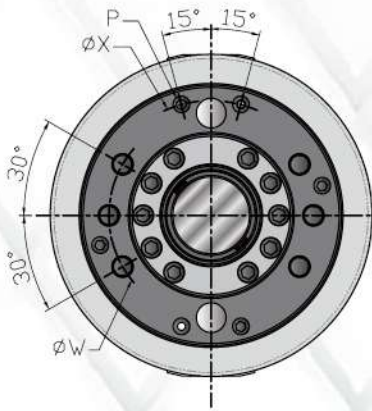

外觀尺寸 / Dimensions

單位：mm

型號 Model	尺寸 Dimension															吊環孔 Screw rings
	A1	A	B	C (max)	C (min)	D (max)	D (min)	E	F	G	H	I	J	K	L (max)	
CH05-2JA4	63.5	54	14	21.3	6	25.92	23.61	33	45	110	135	26	71	20	16	
CH06-2JA5	82.55	66	20	23.75	8.25	32.5	29.7	45	60	140	169	29	91	19	26	
CH08-2JA6	106.36	95	25	30	10.5	38.7	35	52	66	170	210	39	103	20.5	31.5	
CH10-2JA8	139.7	110	30	35	11	51	46.6	75	94	220	254	43	113	25	26.5	

型號 Model	尺寸 Dimension																			吊環孔 Screw rings
	L (min)	M	N	P	Q	R	S	T	U	W	X	Y	Z	a	b	d	f	g		
CH05-2JA4	6	4	15	M6	M40XP1.5	23	4-M10X75L	118	M6	82.6	96	2	2	10	M8	15	8X16X4	100		
CH06-2JA5	14	5	15	M6	M55XP2.0	26	6-M10X95L	146	M8	104.8	116	3	2	12	M10	15	10X22X4			
CH08-2JA6	15.5	5	17	M6	M60XP2.0	35	6-M12X110L	179	M8	133.4	150	3	2	14	M12	15	12X27X5		M10	
CH10-2JA8	7.5	5	18	M8	M85XP2.0	40	6-M16X120L	224.5	M10	171.4	190	3	2	16	M12	15	14X28X5		M10	

技術資料 / Technical Data

型號 Model	尺寸 Dimension	主軸端 尺寸 Spindle nose size	通孔 直徑 Thru-Hole mm	夾持直徑範圍 Gripping range mm		活塞 行程 Plunger Stroke mm	爪行程 (直徑) Jaw Stroke (diameter) mm	容許最大 入力 Max Draw Bar Force kN (kgf)	最大靜止 把握力 Max Gripping Force kN (kgf)	容許最高 迴轉速度 Max Speed min ⁻¹ (r.p.m)	重量 (含標準軟爪) Net Weight with Soft top jaws kg	轉動 慣量 Moment of inertia kg · m ²	最大 壓力 Max pressure MPa(kgf/cm ²)	搭配 硬爪 Matching Hard top jaw	搭配 軟爪 Matching Soft top jaw	搭配迴轉油壓缸 Matching Cylinder
				Max.	Min.											
CH05-2JA4	A2-4	33	135	12	10	4.6	11.7(1193)	24(2447)	7000	6.5	0.017	註1 (Mark1)	HJ05	SJ05	RHC-10系列	
CH06-2JA5	A2-5	45	169	14	12	5.5	14.5(1479)	38(3875)	6000	11.5	0.05		HJ06	SJ06	RHC-12系列、RHC-S13系列	
CH08-2JA6	A2-6	52	210	14	16	7.4	23.2(2366)	57.3(5843)	5000	23	0.13		HJ08	SJ08	RHC-15系列、RHC-S14系列	
CH10-2JA8	A2-8	75	254	31	19	8.8	28.5(2906)	74(7546)	4200	36.4	0.28		HJ10	SJ10	RHC-18系列、RHC-S17系列	

註1：最大壓力 = (容許最大入力) ÷ (搭配迴轉液壓缸活塞拉力端面面積) / 註2：限用二硫化鉬作為潤滑用脂 / 註3：每8小時潤滑

Remark 1: Maximum Pressure = (maximum input power) ÷ (Mating with the rotary cylinder's pulling side piston area)

Remark 2: Using only MoS2 as lubricant.

Remark 3: Lubricate per 8 hours

4-Jaw

4 Jaw High Precision Thru-Hole Chuck Series

特色 / Product Features

- 1.適用於夾持方形類或不規則形狀物件切削加工。
- 2.採用高級合金鋼，且重要零件皆經硬化處理，加強結構剛性，提昇穩定之精度與使用壽命。
- 3.採中空大孔徑貫通設計，方便長形棒材類加工，並可搭配使用自動化設備，提高產能。
- 4.搭配迴轉缸，提供穩定壓力夾持工件，可適用於廣泛加工條件。
- 5.專業精密研磨使其具有高精度、精密重複夾持精度、高夾持力。

- 1.Suitable for square or irregular shape objects to clamp for cutting process.
- 2.Using the advanced high-strength alloy steel, the key components have been treated with hardening which is strengthening the structure and enhancing the stability with accuracy and durability.
- 3.Large caliber design allowing the bar material go through, furthermore, it can be complemented to automatic processing equipment for enhancing the machining efficiency.
- 4.The chucks complement the rotary hydraulic cylinder to provide a stable pressure for various chucking conditions.

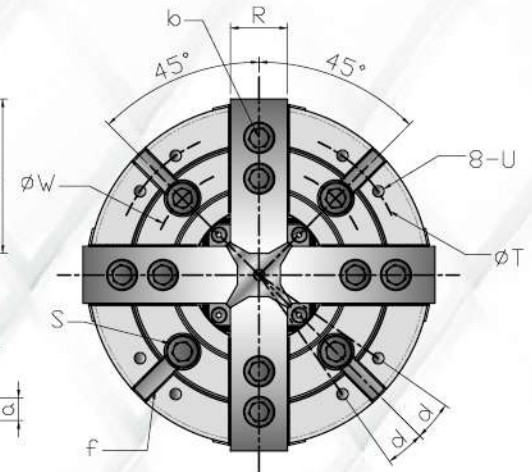
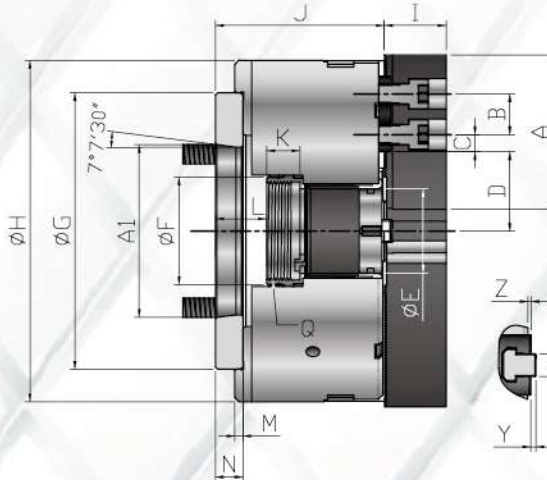
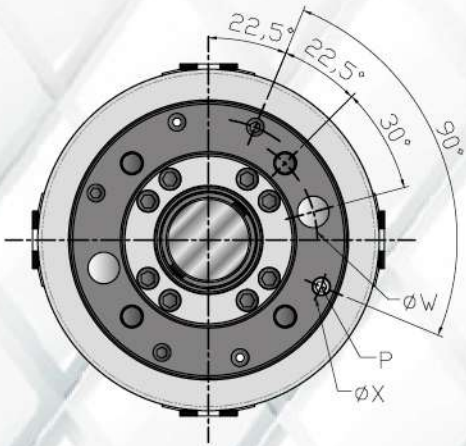

外觀尺寸 / Dimensions

單位：mm

型號 Model	尺寸 Dimension														
	A1	A	B	C (max)	C (min)	D (max)	D (min)	E	F	G	H	I	J	K	L (max)
CH06-4JA5	82.55	66	20	23.75	8.25	32.5	29.7	45	60	140	169	29	91	19	26
CH08-4JA6	106.36	95	25	30	10.5	38.7	35	52	66	170	210	39	103	20.5	31.5
CH10-4JA8	139.7	110	30	35	11	51	46.6	75	94	220	254	43	113	25	26.5

型號 Model	尺寸 Dimension																	吊環孔 Screw rings
	L (min)	M	N	P	Q	R	S	T	U	W	X	Y	Z	a	b	d	f	
CH06-4JA5	14	5	15	M6	M55XP2.0	26	4-M10X95L	146	M8	104.8	116	3	2	12	M10	10	10X22X4	
CH08-4JA6	15.5	5	17	M6	M60XP2.0	35	4-M12X110L	179	M8	133.4	150	3	2	14	M12	10	12X27X5	M10
CH10-4JA8	7.5	5	18	M8	M85XP2.0	40	4-M16X120L	224.5	M10	171.4	190	3	2	16	M12	10	14X28X5	M10

技術資料 / Technical Data

型號 Model	尺寸 Dimension	主軸端 尺寸 Spindle nose size	通孔 直徑 Thru-Hole mm	夾持直徑範圍 Gripping range mm		活塞 行程 Plunger Stroke mm	爪行程 (直徑) Jaw Stroke (diameter)	容許最大 入力 Max Draw Bar Force kN (kgf)	最大靜止 把握力 Max Gripping Force kN (kgf)	容許最高 迴轉速度 Max Speed min ⁻¹ (r.p.m)	重量 (含標準軟爪) Net Weight with Soft top jaws kg	轉動 慣量 Moment of inertia kg · m ²	最大 壓力 Max pressure MPa(kgf/cm ²)	搭配 硬爪 Matching Hard top jaw	搭配 軟爪 Matching Soft top jaw	搭配迴轉油壓缸 Matching Cylinder
				Max.	Min.											
CH06-4JA5		A2-5	45	169	15	12	5.5	22(2243)	57(5812)	4500	13.7	0.04	註1 (Mark1)	HJ06	SJ06	RHC-12系列、RHC-S13系列
CH08-4JA6		A2-6	52	210	20	16	7.4	34.9(3558)	89(9075)	4300	24	0.11		HJ08	SJ08	RHC-15系列、RHC-S14系列
CH10-4JA8		A2-8	75	254	25	19	8.8	43(4385)	111(11319)	3200	41.5	0.25		HJ10	SJ10	RHC-18系列、RHC-S17系列

註1：最大壓力 = (容許最大入力) ÷ (搭配迴轉油壓缸活塞拉力端面積) / 註2：限用二硫化鉬作為潤滑用脂 / 註3：每8小時潤滑

Remark 1 : Maximum Pressure = (maximum input power) ÷ (Mating with the rotary cylinder's pulling side piston area)

Remark 2 : Using only MoS2 as lubricant.

Remark 3 : Lubricate per 8 hours



CBH3J 三爪中空大孔徑精密動力夾頭系列



3-Jaw

3 Jaw Extra Large Caliber Thru-Hole Chuck Series

特色 / Product Features

1. 適用於夾持圓形棒材物件切削加工。
 2. 加大通孔：孔徑較同標準規格加大，適用於較大直徑棒料加工。
 3. 使用高級合金鋼材，且經硬化處理強化結構，使其擁有高強度、高剛性、高壽命之特性。
 4. 專業精密研磨使其具有高精密度、精密重複夾持精度、高夾持力。
1. Suitable for round-bar shape objects to clamp for cutting process.
 2. Large thru-hole design : Thru-hole dimension is much larger than standard specification, suitable for large diameter bar object to be clamped.
 3. Adopting high-strength alloy steel through hardening treatment with high intensity, rigidity and durability.
 4. The chucks through professional precisely grinding to obtain the high precision, high clamping force and great repeatedly clamping accuracy.

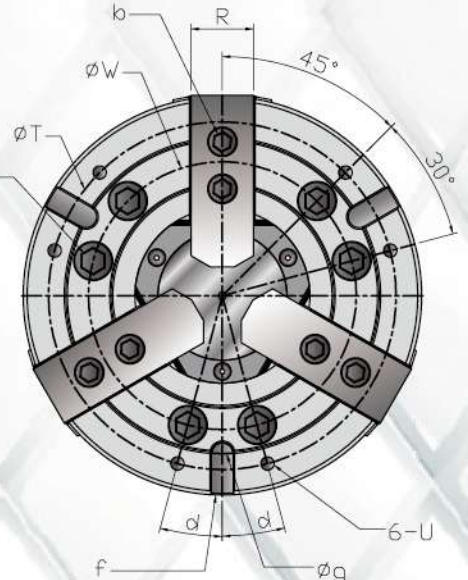
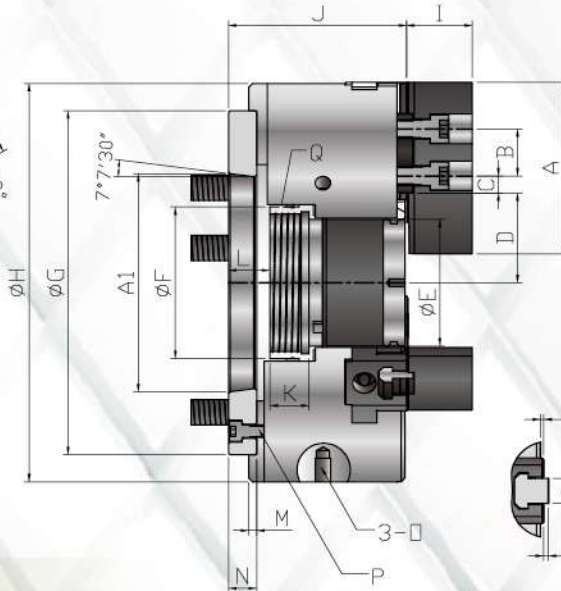
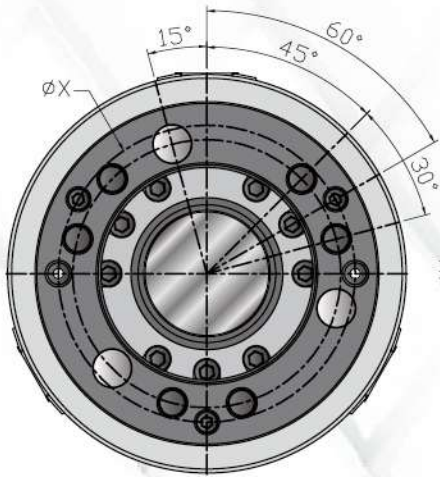

單位：mm

外觀尺寸 / Dimensions

型號 Model	A1	A	B	C (max)	C (min)	D (max)	D (min)	E	F	G	H	I	J	K	L (max)	L (min)
CBH06-3JA5	82.55	66	20	23.75	8.25	35.19	32.42	52	66	140	175	29	94.5	19	26	14
CBH08-3JA6	106.36	95	25	30	10.5	45.09	41.39	66	81	170	225	39	105.5	20.5	31.5	15.5
CBH10-3JA8	139.7	110	30	35	11	53.38	48.99	81	97	220	255	43	113	25	26.5	7.5

型號 Model	M	N	O	P	Q	R	S	T	U	W	X	Y	Z	a	b	d	f	g
CBH06-3JA5	5	15		M6	M60XP2.0	26	6-M10X100L	145.5	M8	104.8	116	3	2	12	M10	15	10X21X4	130
CBH08-3JA6	5	17	M10	M6	M75XP2.0	35	6-M12X115L	183.5	M8	133.4	150	3	2	14	M12	15	12X31X5	160
CBH10-3JA8	5	18	M10	M8	M90XP2.0	40	6-M16X120L	222.5	M10	171.4	190	3	2	16	M12	15	14X26X5	200

技術資料 / Technical Data

型號 Model	主軸端 尺寸 Spindle nose size	通孔 直徑 Thru-Hole mm	夾持直徑範圍 Gripping range mm		活塞 行程 Plunger Stroke mm	爪行程 (直徑) Jaw Stroke (diameter)	容許最大 入力 Max Draw Bar Force kN (kgf)	最大靜止 把握力 Max Gripping Force kN (kgf)	容許最高 迴轉速度 Max Speed min ⁻¹ (r.p.m)	重量 (含標準軟爪) Net Weight with Soft top jaws kg	轉動 慣量 Moment of inertia kg · m ²	最大 壓力 Max pressure MPa(kgf/cm ²)	搭配 硬爪 Matching Hard top jaw	搭配 軟爪 Matching Soft top jaw	搭配迴轉液壓缸 Matching Cylinder
			Max.	Min.											
CBH06-3JA5	A2-5	52	175	19	12	5.5	20.0 (2039)	58.5 (5965)	6000	12.7	0.0555	註1 (Mark1)	HJ06	SJ06	RHC-12系列、RHC-S13系列
CBH08-3JA6	A2-6	66	225	23	16	7.4	32 (3263)	99.0 (10095)	5000	25	0.156		HJ08	SJ08	RHC-15系列、RHC-S14系列
CBH10-3JA8	A2-8	81	255	41	19	8.8	48.8 (4976)	126.0 (12848)	4500	34.7	0.319		HJ10	SJ10	RHC-18系列、RHC-S17系列

註1：最大壓力 = (容許最大入力) ÷ (搭配迴轉液壓缸活塞拉力端面面積) / 註2：限用二硫化鋁作為潤滑用脂 / 註3：每8小時潤滑

Remark 1 : Maximum Pressure = (maximum input power) ÷ (Mating with the rotary cylinder's pulling side piston area)

Remark 2 : Using only MoS2 as lubricant.

Remark 3 : Lubricate per 8 hours



CBH2J 二爪中空大孔徑精密動力夾頭系列



2-Jaw

2 Jaw Extra Large Caliber Thru-Hole Chuck Series

特色 / Product Features



- 適用於夾持不規則形狀物件切削加工。
 - 加大通孔：孔徑較同標準規格加大，適用於較大直徑棒料加工。
 - 使用高級合金鋼材，且經硬化處理強化結構，使其擁有高強度、高剛性、高壽命之特性。
 - 專業精密研磨使其具有高精密度、精密重複夾持精度、高夾持力。
- Suitable for irregular shape objects to clamp for cutting process.
 - Large thru-hole design : Thru-hole dimension is much larger than standard specification, suitable for processing large diameter bar objects.
 - Adopting high-strength alloy steel through hardening treatment with high intensity, rigidity and durability.
 - The chucks through professional and precisely grinding to obtain the high precision, high clamping force and great repeatedly clamping accuracy.

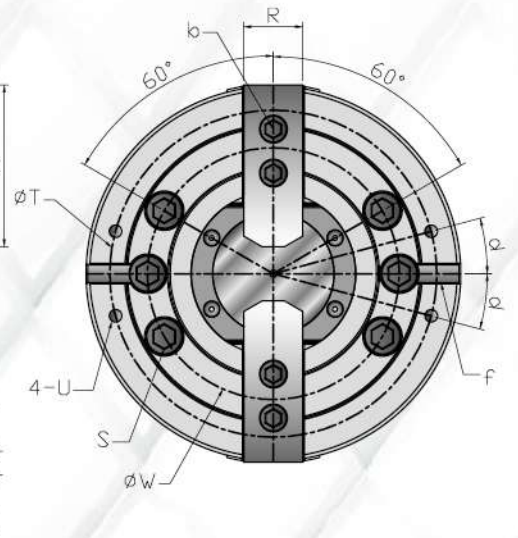
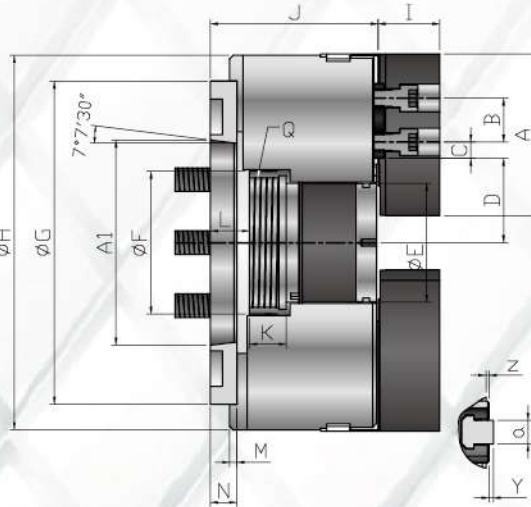
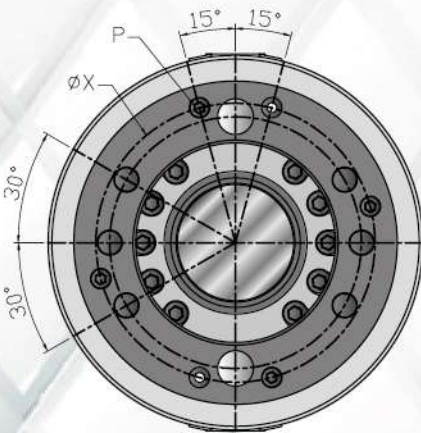

外觀尺寸 / Dimensions

單位：mm

型號 Model	尺寸 Dimension	A1	A	B	C (max)	C (min)	D (max)	D (min)	E	F	G	H	I	J	K	L (max)
CBH06-2JA5		82.55	66	20	23.75	8.25	35.19	32.42	52	66	140	175	29	94.5	19	26
CBH08-2JA6		106.36	95	25	30	10.5	45.09	41.39	66	81	170	225	39	105.5	20.5	31.5
CBH10-2JA8		139.7	110	30	35	11	53.38	48.99	81	97	220	255	43	113	25	26.5

型號 Model	尺寸 Dimension	L (min)	M	N	P	Q	R	S	T	U	W	X	Y	Z	a	b	d	f	吊環孔 Screw rings
CBH06-2JA5		14	5	15	M6	M60XP2.0	26	6-M10X100L	145.5	M8	104.8	116	3	2	12	M10	15	10X26X4	
CBH08-2JA6		15.5	5	17	M6	M75XP2.0	35	6-M12X115L	183.5	M8	133.4	150	3	2	14	M12	15	12X35X5	M10
CBH10-2JA8		7.5	5	18	M8	M90XP2.0	40	6-M16X120L	222.5	M10	171.4	190	3	2	1	M12	15	14X29X5	M10

技術資料 / Technical Data

型號 Model	尺寸 Dimension	主軸端 尺寸 Spindle nose size	通孔 直徑 Thru-Hole mm	夾持直徑範圍 Gripping range mm		活塞 行程 Plunger Stroke mm	爪行程 (直徑) Jaw Stroke (diameter)	容許最大 入力 Max Draw Bar Force kN (kgf)	最大靜止 把握力 Max Gripping Force kN (kgf)	容許最高 迴轉速度 Max Speed min ⁻¹ (r.p.m)	重量 (含標準軟爪) Net Weight with Soft top jaws kg	轉動 慣量 Moment of inertia kg · m ²	最大 壓力 Max pressure MPa(kgf/cm ²)	搭配 硬爪 Matching Hard top jaw	搭配 軟爪 Matching Soft top jaw	搭配迴轉油壓缸 Matching Cylinder
				Max.	Min.											
CBH06-2JA5		A2-5	52	175	19	12	5.5	13.3 (1356)	38.9 (3967)	6000	12.4	0.0561	註1 (Mark1)	HJ06	SJ06	RHC-12系列、RHC-S13系列
CBH08-2JA6		A2-6	66	225	23	16	7.4	21.3 (2172)	65.9 (6720)	5000	23.2	0.1577		HJ08	SJ08	RHC-15系列、RHC-S14系列
CBH10-2JA8		A2-8	81	255	41	19	8.8	32.5 (3314)	83.9 (8555)	4500	33.7	0.3228		HJ10	SJ10	RHC-18系列、RHC-S17系列

註1：最大壓力 = (容許最大入力) ÷ (搭配迴轉液壓缸活塞拉力端面面積) / 註2：限用二硫化鋁作為潤滑用脂 / 註3：每8小時潤滑

Remark 1 : Maximum Pressure = (maximum input power) ÷ (Mating with the rotary cylinder's pulling side piston area)

Remark 2 : Using only MoS2 as lubricant.

Remark 3 : Lubricate per 8 hours

3-Jaw

3 Jaws High Precision Blocked-Center Hydraulic Power Chuck Series

特色 / Product Features

1. 適用於夾持圓形棒材物件切削加工。
 2. 中心為閉式夾頭具有防切削液、雜質作用
 3. 適合一般夾緊應用，並亦可適用於立式加工應用
 4. 專業精密研磨使其具有高精度度、精密重複夾持精度、高夾持力
1. Suitable for non-through regular-shape objects to clamp for cutting process.
 2. The blocked-center design can prevent cutting fluid or cutting scraps entering inside of the structure.
 3. Suitable for normal machinery clamping and also suit for vertical machinery clamping processing.
 4. The chucks through professional precisely grinding to obtain high precision, high clamping force and great repeatedly clamping accuracy.

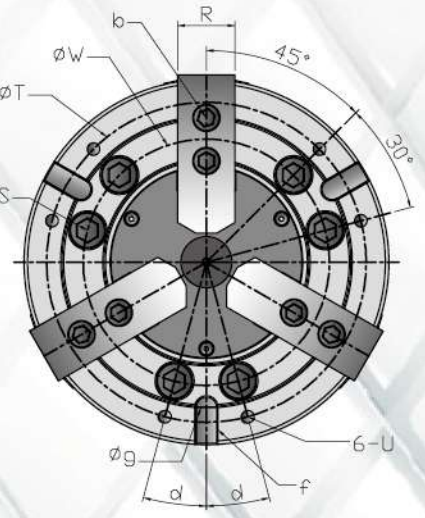
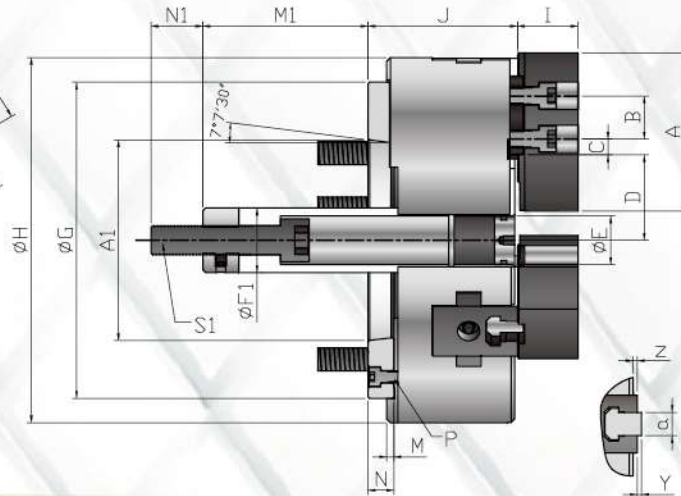
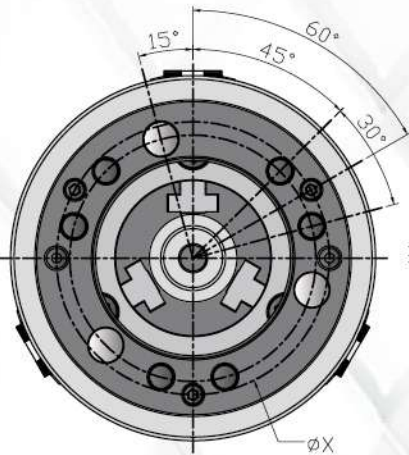

外觀尺寸 / Dimensions

單位：mm

型號 Model	尺寸 Dimension	A1	A	B	C (max)	C (min)	D (max)	D (min)	E	F1	G	H	I	J	M	M1 (max)
CNV06-3JA5		82.55	66	20	14	7.5	40.6	35.98	20	34	140	165	31	84	5	86.5
CNV08-3JA6		106.36	95	25	23	11	45.37	40.52	25	38	170	210	42	97	5	110
CNV10-3JA8		139.7	110	30	31	11	51.1	46.7	34	45	220	254	46	102	5	140

型號 Model	尺寸 Dimension	M1 (min)	N	N1	P	R	S	S1	T	U	W	X	Y	Z	a	b	d	f	g	吊環孔 Screw rings
CNV06-3JA5		66.5	15	36	M6	26	6-M10X90L	M16	145	M8	104.8	116	3	4	12	M10	15	10X16X4	130	
CNV08-3JA6		89	17	36	M6	35	6-M12X105L	M20	183.5	M8	133.4	150	3	5	14	M12	15	12X24X5	160	M10
CNV10-3JA8		115	18	36	M8	40	6-M16X110L	M20	222.5	M10	171.4	190	3	5	16	M12	15	14X25X5	200	M10

技術資料 / Technical Data

型號 Model	尺寸 Dimension	主軸端 尺寸 Spindle nose size	夾持直徑範圍 Gripping range mm		活塞 行程 Plunger Stroke mm	爪行程 (直徑) Jaw Stroke (diameter)	容許最大 入力 Max Draw Bar Force kN (kgf)	最大靜止 把握力 Max Gripping Force kN (kgf)	容許最高 迴轉速度 Max Speed min ⁻¹ (r.p.m)	重量 (含標準軟爪) Net Weight with Soft top jaws kg	轉動 慣量 Moment of inertia kg · m ²	最大 壓力 Max pressure MPa(kgf/cm ²)	搭配 硬爪 Matching Hard top jaw	搭配 軟爪 Matching Soft top jaw	搭配迴轉油壓缸 Matching Cylinder
			Max.	Min.											
CNV06-3JA5		A2-5	165	19	20	9.2	18.0 (1835)	52.5 (5353)	5270	14	0.05	註1 (Mark1)	HJ06	SJ06	RHC-M105 · RHC-M105S
CNV08-3JA6		A2-6	210	11	21	9.6	25.0 (2549)	75.0 (7648)	4760	27	0.148		HJ08	SJ08	RHC-M125 · RHC-M125S
CNV10-3JA8		A2-8	254	15	25	8.8	29.0 (2957)	108 (11013)	4010	40	0.328		HJ10	SJ10	RHC-M150 · RHC-M150S

註1：最大壓力 = (容許最大入力) ÷ (搭配迴轉液壓缸活塞拉力端面積) / 註2：限用二硫化鉬作為潤滑用脂 / 註3：每8小時潤滑

Remark 1: Maximum Pressure = (maximum input power) ÷ (Mating with the rotary cylinder's pulling side piston area)

Remark 2: Using only MoS2 as lubricant.

Remark 3: Lubricate per 8 hours

Precision Collet Chuck Serie

特色 / Product Features



1. 前推式設計筒夾夾頭，通過設計裝置部件，實現高度軸向定位精度。
 2. 可快速簡單的安裝至所有車床且可與夾頭相互置換不必更換拉管。
 3. 快拆式設計：可快速拆卸前擋蓋只需更換彈性筒夾，即可立即車削不同尺寸或不同外形材料加工(圓形、方形、六角型)提高效率與通用性。
 4. 特殊硬化處理，實現高剛性高精度穩定性和高使用壽命。
1. Push type collet chuck fixtures can perform high accuracy of axial position locating by the components and mechanical structure design.
 2. The collet chuck could be installed onto the lathe machines rapidly and easily without changing the pulling-pipe when it is switched with the exist chuck.
 3. Quick-release: The design can remove the front cover for switching the collet chuck rapidly in order to gripping various dimensions or shapes (round, square, hexagon) of raw material.
 4. The components through special technology of hardening treatment to achieve high intensity, high rigidity and well durability.

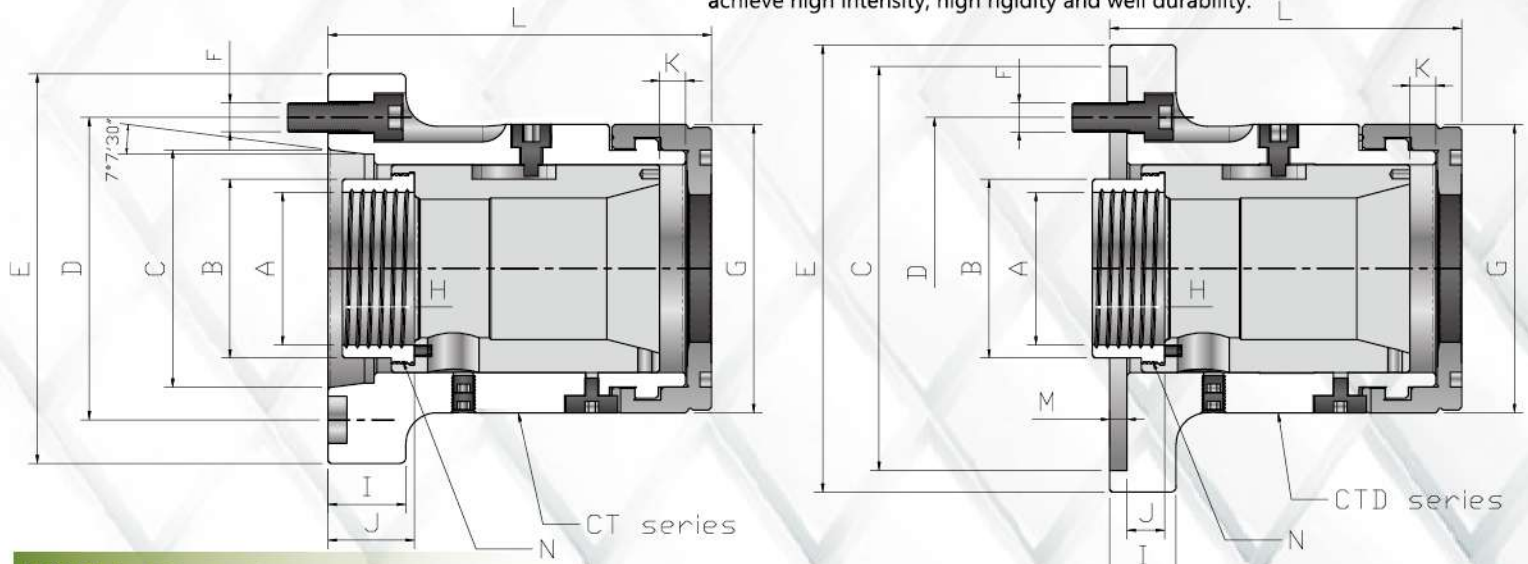

外觀尺寸 / Dimensions

單位：mm

型號 Model	尺寸 Dimension	A	B	C	D	E	F	G	H	I	J (min)	J (max)	K (夾緊位置)	K (安裝位置)	L	M	N
CT30-A4	M40XP1.5	45	63.5	82.6	112	3-M10X35L	85	15	30	23	28	2	6	109		M50XP1.5	
CT42-A5	M55XP2.0	60	82.55	104.8	135	4-M10X30L	100	20	27	30	37	2.5	8.5	133		M66XP1.5	
CT52-A6	M60XP2.0	70	106.36	133.4	170	4-M12X40L	110	15	34.4	30	37	2.5	8.5	133		M70XP1.5	
CT60-A6	M75XP2.0	82	106.36	133.4	170	4-M12X30L	130	15	27	30	37	2.5	8.5	149		M90XP1.5	
CTD42-140	M55XP2.0	60	140	104.8	155	4-M10X25L	100	20	26	15	22	2.5	8.5	124	6	M66XP1.5	
CTD60-170	M75XP2.0	82	170	133.4	185	6-M12X30L	130	15	32	13	20	2.5	8.5	138	6	M90XP1.5	

技術資料 / Technical Data

型號 Model	尺寸 Dimension	主軸端 尺寸 Spindle nose size	通孔直徑 Thru-Hole mm	夾持直徑範圍 Gripping range mm			滑套行程 Sleeve Stroke mm	容許最大 入力 Max Draw Bar Force kN (kgf)	最大靜止 把握力 Max Gripping Force kN (kgf)	容許最高 迴轉速 Max Speed min ⁻¹ (r.p.m)	重量 Net Weight kg	搭配筒夾 Matching Collet
				圓棒 Round	六角材 Hexagon	方材 Square						
CT30-A4		A2-4	30	φ3~30	4~25	5~20	5	20(2039)	44(4486)	7000	4.2	163E
CT42-A5		A2-5	42	φ3~42	6~35	6~29	7	25(2549)	55(5608)	6000	6.5	173E
CT52-A6		A2-6	52	φ3~52	6~44	6~36	7	27.4(2800)	59(6020)	6000	9.4	177E
CT60-A6		A2-6	60	φ3~60	8~51	7~42	7	30(3059)	65(6628)	5000	11.9	185E
CTD42-140			42	φ3~42	6~35	6~29	7	25(2549)	55(5608)	6000	6.8	173E
CTD60-170			60	φ3~60	8~51	7~42	7	30(3059)	65(6628)	5000	11.8	185E

註1：彈性筒夾使用DIN6343規範 / 註2：前擋蓋需每日拆卸清潔

Remark 1 : Uses the spring collet to DIN6343 specification only / Remark 2 : Front cover needs to be dismantled and clean up daily

High Speed

Thru-Hole Precision Rotary Cylinder

特色 / Product Features



1. 提供穩定推拉力。
 2. 具有高速迴轉功能。
 3. 可使用液壓力範圍 35- 40.8 kg/cm² (0.35 - 4 MPa)
 4. 採中空大孔徑貫通設計，可搭配自動化設備加工功能。
 5. 採用高級鋁合金及高強度合金鋼材，且重要零件皆經硬化處理，達到產品輕量化與結構強化目標，提昇穩定之精度與使用壽命。
 6. 產品設計有逆止閥機構，為防止斷電瞬間失壓之安全裝置。
1. Provide a stable thrust and pulling force.
 2. High-speed rotation function
 3. Fit to oil hydraulic range: 35-40.8 kg/cm² (0.35 - 4 MPa)
 4. Large caliber thru-hole design support for processing function of automatic equipment.
 5. Using advanced aluminum alloy and high-strength alloy steel, the key components of the rotary cylinder have been treated with hardening which is strengthening the structure and enhancing the stability with accuracy and durability.
 6. The product is equipped with (check valve) as the safety device to avoid the instant or unexpected pressure loss when the power is off.

使用示意圖 / Application Illustration

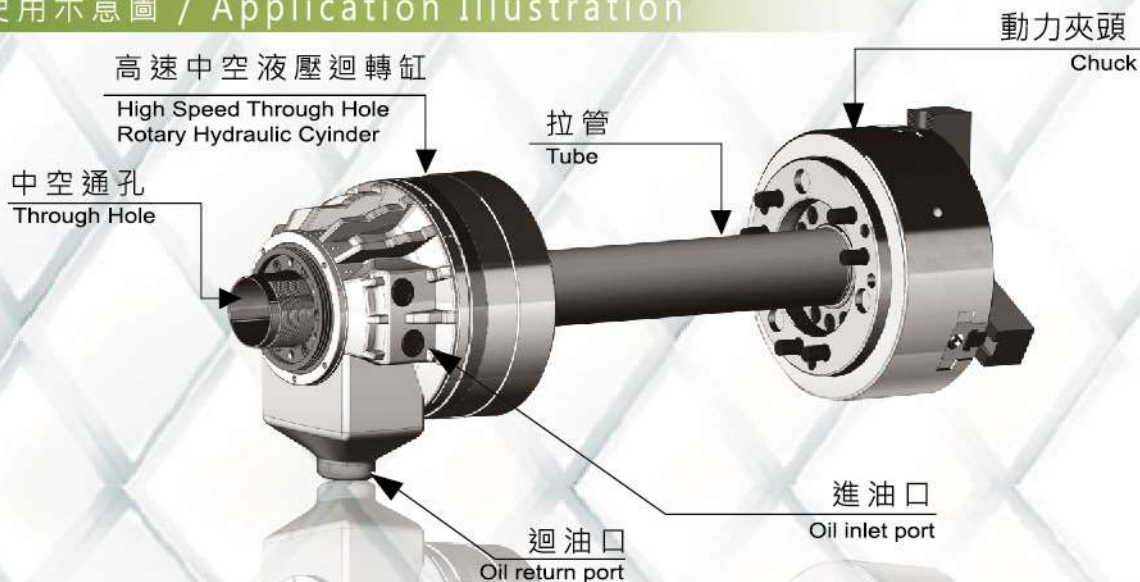

產品介紹 / Production Introduction

為因應目前工業量產化需求，自動化與穩定生產已成為驅勢主流，在此前提下 **AUTO CLAWS** 致力於製造高品質高速中空液壓迴轉缸，以提供客戶高效穩定生產之需求，並達到提高產能之目的。此外本產品更兼顧安全上的考量，構造設計有保護裝置，當系統斷電或瞬間失壓時，透過內置式安全保護裝置作用下，保障夾持力不會隨之突降，以確保使用者操作安全。

Automation and stable mass production have become the tendency and mainstream under the modern industrialization. On this premise, **AUTO CLAWS** is committed to manufacturing high-speed thru-hole rotary hydraulic cylinder, providing customers with efficient and stable production needs and increase productivity.

Moreover, our products are more concerns about safety considerations, configured with a protection device, when the system is powered down or instant loss of pressure, with built-in function of the security device, safeguard chucking power will not suddenly drop, to ensure the safety of the operator.

Adhere to the best quality and intentions of excellent service



RHC-S 中空精密短型液壓迴轉缸系列



High Speed

Thru-Hole Short Type (Compact) Precision Rotary Cylinder Series

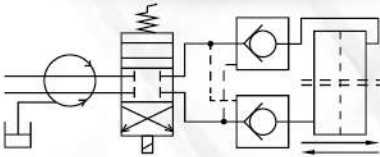
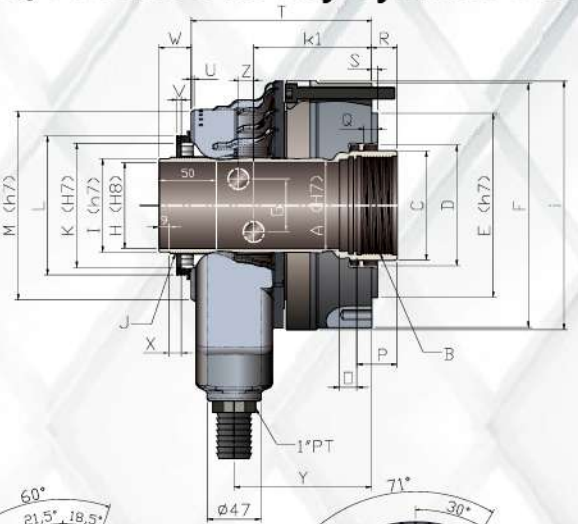
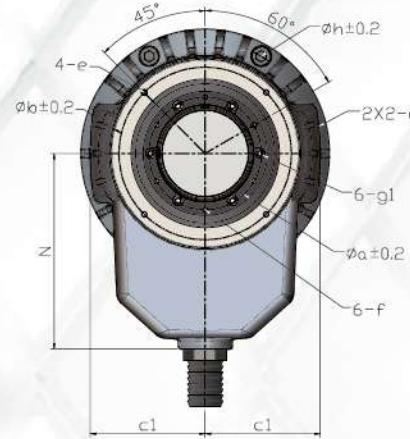

逆止迴流閥機構 (check valve)

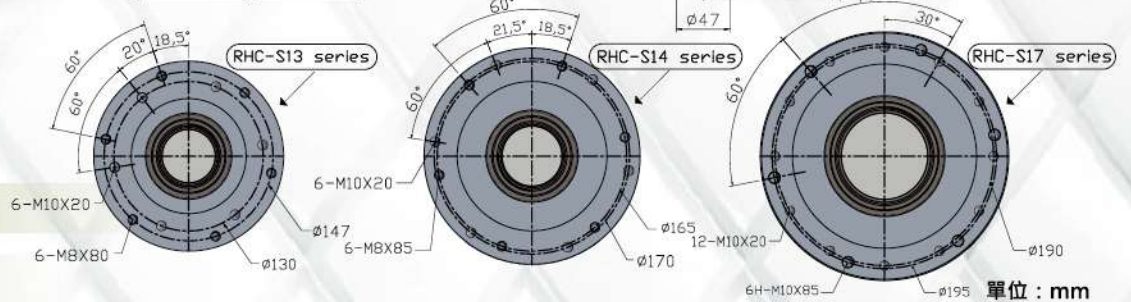

外觀尺寸 / Dimensions

型號 Model	A (H7)	B	C	D	E (H7)	F	G	H (H8)	I (H7)	J	K (H7)	L	M (H7)	N	O	P	Q	R (max)	R (min)	S
RHC-S1336	38	M42XP1.5	65	75	100	165	40	36	50	M52XP1.5	76	85	118	130	15	25	10	13	-3	4
RHC-S1346	50	M55XP2.0	65	75	100	165	40	46	50	M52XP1.5	76	85	118	130	15	30	10	13	-3	4
RHC-S1446	50	M55XP2.0	70	80	130	188	40	46	56	M58XP1.5	85	96	135	140	15	30	12	19	-3	5
RHC-S1452	55	M60XP2.0	70	80	130	188	40	52	56	M58XP1.5	85	96	135	140	15	30	12	19	-3	5
RHC-S1768	70	M75XP2.0	95	105	160	214	46	68	81	M84XP2.0	108	121	164	170	15	35	11	22	-3	5
RHC-S1775	80	M85XP2.0	95	105	160	214	46	75	81	M84XP2.0	108	121	164	170	15	35	11	22	-3	5
RHC-S1777	82	M87XP2.0	95	105	160	214	46	77	81	M84XP2.0	108	121	164	170	15	35	11	22	-3	5

型號 Model	T	U	V	W (max)	W (min)	X (max)	X (min)	Y	Z	a	b	c1	d	e	f	g1	h	i	k1
RHC-S1336	131	3	4	45	29	30	14	102.6	10.5	64	103.5	76	Rc3/8	M5	M6	M5	147	165	90.5
RHC-S1346	131	3	4	45	29	30	14	102.6	10.5	64	103.5	76	Rc3/8	M5	M6	M5	147	165	90.5
RHC-S1446	137.45	3	4	48.55	26.55	36	14	109.7	8.5	73	120	83.5	Rc3/8	M6	M6	M5	165	188	97.7
RHC-S1452	137.45	3	4	48.55	26.55	36	14	109.7	8.5	73	120	83.5	Rc3/8	M6	M6	M5	165	188	97.7
RHC-S1768	157	2.5	4	53	28	39	14	119.6	13.25	98	150	100	Rc1/2	M6	M6	M5	195	216	102.63
RHC-S1775	157	2.5	4	53	28	39	14	119.6	13.25	98	150	100	Rc1/2	M6	M6	M5	195	216	102.63
RHC-S1777	157	2.5	4	53	28	39	14	119.6	13.25	98	150	100	Rc1/2	M6	M6	M5	195	216	102.63

技術資料 / Technical Data

型號 Model	活塞行程 Piston stroke mm	活塞直徑 Piston Dia mm	活塞面積 Piston Area		拉桿 Draw Bar		容許最高 迴轉速度 Max Speed mm ² (r.p.m)	最大工作壓力 Max Operation Pressure MPa(kg/cm ²)	總流量 Total Leakage L/min	轉動慣量 Moment Of Inertia Kg. m ²	淨重 Net Weight Kg
			前推端 Push side cm ²	後拉端 Pull side cm ²	前推端 Push side kN(kgf)	後拉端 Pull side kN(kgf)					
RHC-S1336	16	130	106.6	95.5	44.6(4552)	39.9(4077)	8000	4.5(45.9)	3	0.018	10
RHC-S1346	16	130	106.6	95.5	44.6(4552)	39.9(4077)	8000	4.5(45.9)	3	0.018	9.2
RHC-S1446	22	145	132.8	122.6	55.6(5670)	51.3(5234)	6500	4.5(45.9)	3.9	0.034	12.5
RHC-S1452	22	145	132.8	122.6	55.6(5670)	51.3(5234)	6500	4.5(45.9)	3.9	0.034	12
RHC-S1768	25	170	166.2	152	69.5(7095)	63.6(6491)	5400	4.5(45.9)	4.2	0.066	19
RHC-S1775	25	170	166.2	152	69.5(7095)	63.6(6491)	5400	4.5(45.9)	4.2	0.066	19
RHC-S1777	25	170	166.2	152	69.5(7095)	63.6(6491)	5400	4.5(45.9)	4.2	0.066	19

註1：總流量：壓力3.0MPa (30.6kgf/cm²)、油溫50°C

註2：精密液壓迴轉缸注油端必須使用濾網密度10µm過濾網

註3：限用ISO VG 32或ISO VG 46消泡性循環油

Remark 1 : Total leakage : Pressure 3.0MPa (30.6kgf/cm²) and oil temperature 50°C.

Remark 2 : Circulating oil filter's net density should be under 10µm.

Remark 3 : Use only ISO VG 32 or ISO VG 46 deforming circulating oil.



RHC 中空精密液壓迴轉缸系列



High Speed

Thru-Hole Precision Rotary Cylinder Series

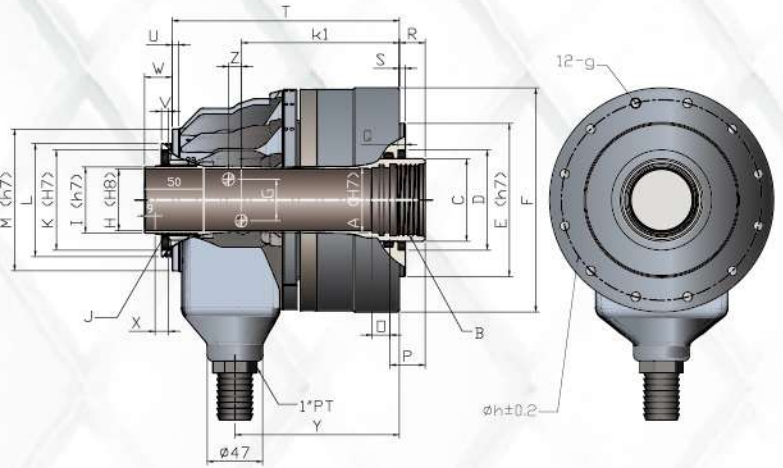
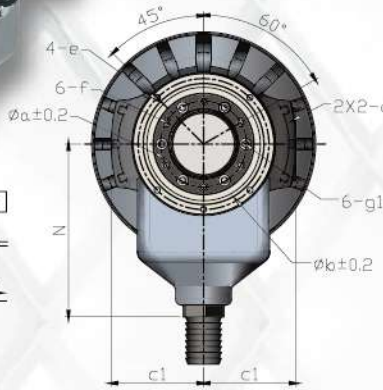
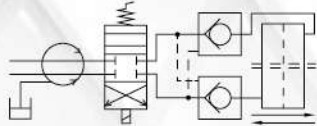

逆止迴流閥機構
(check valve)

外觀尺寸 / Dimensions

單位: mm

型號 Model	尺寸 Dimension	A (H7)	B	C	D	E (H6)	F	G	H (H8)	I (H7)	J	K (H7)	L	M (H7)	N	O	P	Q	R (max)	R (min)
RHC-1036		38	M42XP1.5	48	65	100	136	24	36	42	M44XP1.5	64	73	103	107	15	25	6	15	0
RHC-1038		40	M44XP1.5	50	65	100	136	24	38	42	M44XP1.5	64	73	103	107	15	25	6	15	0
RHC-1236		38	M42XP1.5	65	80	100	155	34	36	50	M52XP1.5	76	85	110	122	15	25	6	15	0
RHC-1246		50	M55XP2.0	65	80	100	155	34	46	50	M52XP1.5	76	85	110	122	15	30	6	15	0
RHC-1546		50	M55XP2.0	70	85	130	190	40	46	56	M58XP1.5	85	96	120	136.5	15	30	6	22	0
RHC-1552		55	M60XP2.0	70	85	130	190	40	52	56	M58XP1.5	85	96	120	136.5	15	30	6	22	0
RHC-1868		70	M75XP2.0	95	120	160	215	36	68	81	M84XP2.0	108	121	155	165	15	35	6	25	0
RHC-1875		80	M85XP2.0	95	120	160	215	36	75	81	M84XP2.0	108	121	155	165	15	35	6	25	0
RHC-1877		82	M87XP2.0	95	120	160	215	36	77	81	M84XP2.0	108	121	155	165	20	35	6	25	0

型號 Model	尺寸 Dimension	S	T	U	V	W (max)	W (min)	X (max)	X (min)	Y	Z	a	b	c1	d	e	f	g	g1	h	k1
RHC-1036		5	169.8	3.5	4	39	24	29	14	131	14	52	93	67	RC3/8	M5	M5	M10X15	M4	115	117.1
RHC-1038		5	169.8	3.5	4	39	24	29	14	131	14	52	93	67	RC3/8	M5	M5	M10X15	M4	115	117.1
RHC-1236		5	181.5	6.5	4	37.5	22.5	26.5	11.5	133	13	64	100	76	RC1/2	M5	M6	M10X17	M4	130	126
RHC-1246		5	181.5	6.5	4	37.5	22.5	26.5	11.5	133	13	64	100	76	RC1/2	M5	M6	M10X17	M4	130	126
RHC-1546		5	192	5	6	46	24	33.5	11.5	139.5	10.5	73	111	78.5	RC1/2	M6	M6	M10X20	M5	170	132.5
RHC-1552		5	192	5	6	46	24	33.5	11.5	139.5	10.5	73	111	78.5	RC1/2	M6	M6	M10X20	M5	170	132.5
RHC-1868		5	226.5	8.5	4	48.5	23.5	36.5	11.5	161	17	98	143.5	99	RC1/2	M6	M6	M10X20	M5	190	153
RHC-1875		5	226.5	8.5	4	48.5	23.5	36.5	11.5	161	17	98	143.5	99	RC1/2	M6	M6	M10X20	M5	190	153
RHC-1877		5	226.5	8.5	4	48.5	23.5	36.5	11.5	161	17	98	143.5	99	RC1/2	M6	M6	M10X20	M5	190	153

技術資料 / Technical Data

型號 Model	尺寸 Dimension	活塞行程 Piston stroke mm	活塞直徑 Piston Dia mm	活塞面積 Piston Area		拉桿 Draw Bar		容許最高 迴轉速度 Max Speed mm ² (r.p.m)	最大工作壓力 Max Operation Pressure MPa(kg/cm ²)	總流量 Total Leakage L/min	轉動慣量 Moment Of Inertia Kg . m ²	淨重 Net Weight Kg
				前推端 Push side cm ²	後拉端 Pull side cm ²	前推端 Push side kN(kgf)	後拉端 Pull side kN(kgf)					
RHC-1036		15	105	70.6	66.9	28(2883)	26(2731)	8000	4(40.8)	3	0.016	8.6
RHC-1038		15	105	70.6	66.9	28(2883)	26(2731)	8000	4(40.8)	3	0.016	8.5
RHC-1236		15	125	100.7	89.5	37(3820)	33(3432)	7000	4(40.8)	3	0.019	11
RHC-1246		15	125	100.7	89.5	37(3820)	33(3432)	7000	4(40.8)	3	0.019	10.88
RHC-1546		22	155	160.7	150.2	60(6163)	56(5760)	6200	4(40.8)	3.9	0.053	15.5
RHC-1552		22	155	160.7	150.2	60(6163)	56(5760)	6200	4(40.8)	3.9	0.053	15.47
RHC-1868		25	180	198.2	183.5	74(7601)	69(7037)	4700	4(40.8)	4.2	0.095	24.5
RHC-1875		25	180	198.2	183.5	74(7601)	69(7037)	4700	4(40.8)	4.2	0.095	24.5
RHC-1877		25	180	198.2	183.5	74(7601)	69(7037)	4700	4(40.8)	4.2	0.095	24.5

註1: 總流量: 壓力3.0MPa (30.6kgf/cm²)、油溫50°C

註2: 於精密液壓迴轉缸注油端必須使用濾網密度10µm過濾網

註3: 限用ISO VG 32或ISO VG 46消泡性循環油

Remark 1: Total leakage: Pressure 3.0MPa (30.6kgf/cm²) and oil temperature 50°C.

Remark 2: Circulating oil filter's net density should be under 10µm.

Remark 3: Use only ISO VG 32 or ISO VG 46 deforming circulating oil.

High Speed

Short(Compact) Blocked-Center Type Precision Rotary Cylinder Series

特色 / Product Features

1. 安全:內設置有逆止閥安全機制·增加後鎖設計加強鎖固提昇結構剛性·降低因推力產生之反作用力·亦可靈活使用鎖固方式可從前端或後段安裝鎖固。
2. 短型: 整體結構強化減少長度降低力矩·相對質輕減輕主軸負擔並減少組裝干涉增加機具空間使用率。
3. 質輕: 採用高強度鋁合金搭配使用高強度合金鋼材·減輕重量、慣性·提高強度增加降溫效果。
4. 兩用型: 設計目的為立臥兩用型因此採密閉式內循環迴油系統·可水平或垂直安裝方便使用者所需。
5. 高壽命: 採用高品質結構用鋼材·且經硬化處理強化結構·高品質油封耗材·專業精密研磨·使其擁有高強度、高剛性、高精度、高壽命之特性。

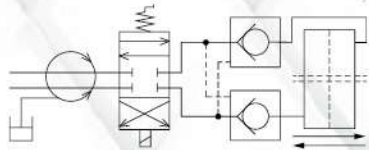
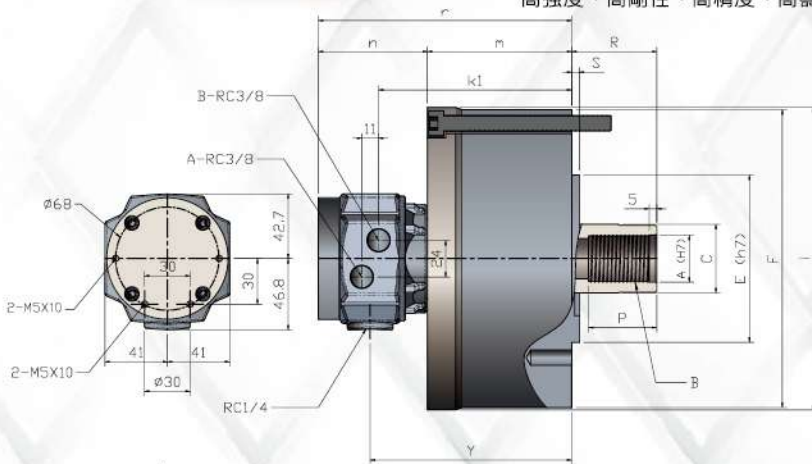

逆止迴流閥機構
(check valve)

1. Safety Device: Whole series of our cylinders are equipped with check valve as the safety device, furthermore, the back-lock design of the cylinder body can strengthen the structure rigidity and decrease the counter-force generated by thrust or pushing force, either the front-lock also can be applied to the cylinder body as well.
2. Short structure design: The short structure design will strengthen the structure, reduce the torque reaction and also decrease both the load of the spindle and the interference when assembling.
3. Light Weight: The cylinder made of high-intensity aluminum alloy and high-strength alloy steel, the structure design can lighten the weight and reduce the rotation inertial effects, and not only strengthen the structure but also increase the cooling effect.
4. Dual-use type: The closed oil cycling system is designed for dual-use for vertical and horizontal machines according to user's requirement.
5. Durability: Adopting high quality steel alloy through hardening treatment and high accuracy professional grinding technology go with superior quality seals, the cylinder can achieve high intensity, high rigidity and well durability features.

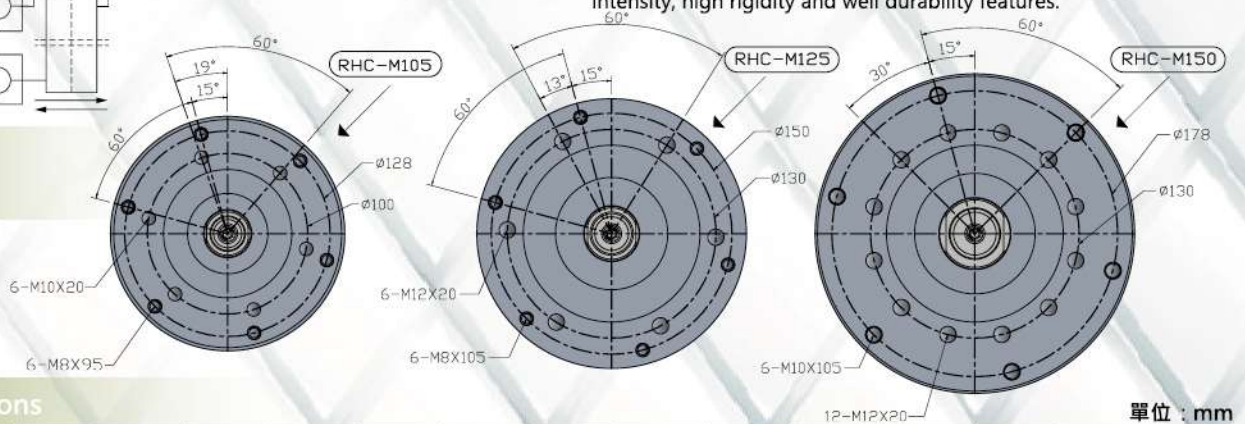

外觀尺寸 / Dimensions

型號 Model	尺寸 Dimension A (H7)	B	C	E (H7)	F	P	R (max)	R (min)	S	Y	i	k1	m	n	r
RHC-M105	21	M20XP2.5	30	80	142	35	45	25	5	118.7	146	113.2	81	71.7	152.7
RHC-M125	25	M24XP3.0	35	110	168	44	51	26	5	128.7	168	123.2	91	71.7	162.7
RHC-M150	31	M30XP3.5	45	110	196	45	56	26	5	134.7	199	129.2	97	71.7	168.7

單位 : mm

技術資料 / Technical Data

型號 Model	尺寸 Dimension Piston stroke mm	活塞直徑 Piston Dia mm	活塞面積 Piston Area		拉桿 Draw Bar		容許最高 迴轉速度 Max Speed min ⁻¹ (r.p.m)	最大工 作壓力 Max Operation Pressure MPa(kgf/cm ²)	總流量 Total Leakage L/min	轉動慣量 Moment Of Inertia kg·m ²	淨重 Net Weight kg
			前推端 Push side cm ²	後拉端 Pull side cm ²	前推端 Push side kN(kgf)	後拉端 Pull side kN(kgf)					
RHC-M105	20	105	82.5	75.5	30.7 (3133)	28 (2864)	6000	4 (40.8)	0.8	0.0135	6.4
RHC-M125	25	125	118.7	109	44.1 (4503)	40.5 (4138)	6000	4 (40.8)	0.8	0.0266	8.9
RHC-M150	30	150	172.7	156.7	64.2 (6552)	58.3 (5949)	5500	4 (40.8)	0.8	0.0505	12

註1: 總流量: 壓力3.0MPa (30.6kgf/cm²)、油溫50°C
 註2: 於精密液壓迴轉缸注油端必須使用濾網密度10μm過濾網
 註3: 限用ISO VG 32或ISO VG 46消泡性循環油

Remark 1: Total leakage: Pressure 3.0MPa (30.6kgf/cm²) and oil temperature 50°C.
 Remark 2: Circulating oil filter's net density should be under 10μm.
 Remark 3: Use only ISO VG 32 or ISO VG 46 deforming circulating oil.



RHC-MS 中實精密短型液壓迴轉缸系列(檢知型) CE

High Speed

Short(Compact) Blocked-Center Type Precision Rotary Cylinder Series (With Detector Device Type)

特色 / Product Features

1. 檢出裝置: 設計有檢出構造裝置通過近接開關, 亦可作為安全感知設置。
2. 安全: 內設置有逆止閥安全機制, 增加後鎖設計加強鎖固提昇結構剛性, 降低因推力產生之反作用力, 亦可靈活使用鎖固方式可從前端或後段安裝鎖固。
3. 短型: 整體結構強化減少長度降低力矩, 相對質輕減輕主軸負擔並減少組裝干涉增加機具空間使用率。
4. 質輕: 採用高強度鋁合金搭配使用高強度合金鋼材, 減輕重量、慣性, 提高強度增加降溫效果。
5. 兩用型: 設計目的為立臥兩用型因此採閉式內循環迴油系統, 可水平或垂直安裝方便使用者所需。
6. 高壽命: 採用高品質結構用鋼材, 且經硬化處理強化結構、高品質油封耗材、專業精密研磨, 使其擁有高強度、高剛性、高精度、高壽命之特性。

1. Sensor System: Through additional mounting the proximity sensor to the detect device, the detector is able to control the cylinder stroke length and being a security detector.
2. Safety Device: Whole series of our cylinders are equipped with check valve as the safety device, furthermore, the back-lock design of the cylinder body can strengthen the structure rigidity and decrease the counter-force generated by thrust or pushing force, either the front-lock also can be applied to the cylinder body as well.
3. Short structure design: The short structure design will strengthen the structure, reduce the torque reaction and also decrease both the load of the spindle and the interference when assembling
4. Light Weight: The cylinder made of high-intensity aluminum alloy and high-strength alloy steel, the structure design can lighten the weight and reduce the rotation inertial effects, and not only strengthen the structure but also increase the cooling effect.
5. Dual-use type: The closed oil cycling system is designed for dual-use for vertical and horizontal machines according to user's requirement.
6. Durability: Adopting high quality steel alloy through hardening treatment and high accuracy professional grinding technology go with superior quality seals, the cylinder can achieve high intensity, high rigidity and well durability features.

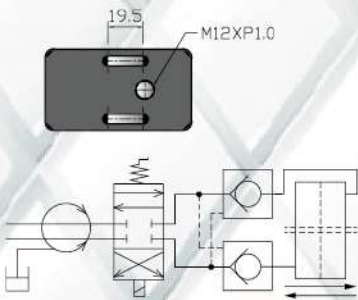
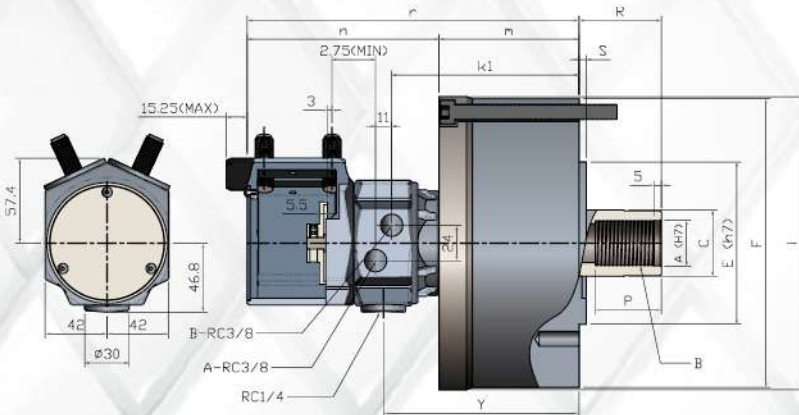

逆止迴流閥機構 (check valve)

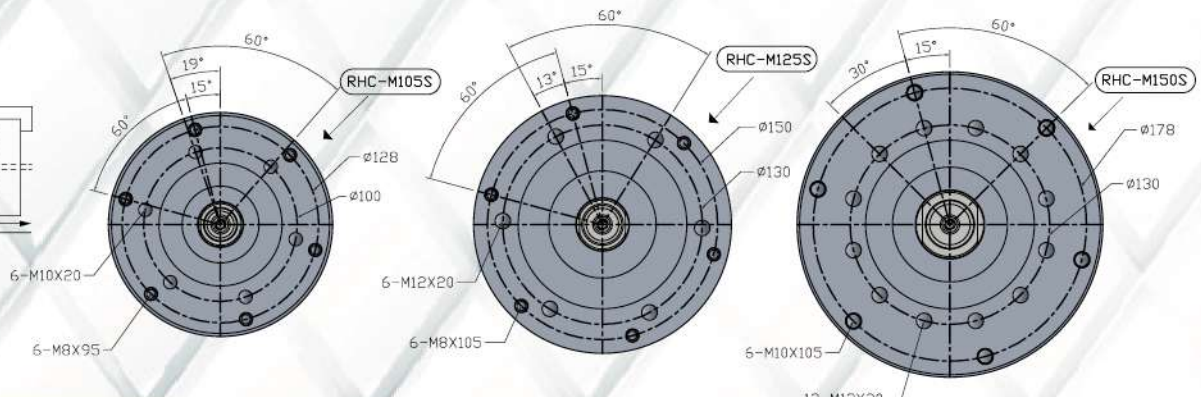

外觀尺寸 / Dimensions

型號 Model	尺寸 Dimension	A (H7)	B	C	E (H7)	F	P	R (max)	R (min)	S	Y	i	k1	m	n	r
RHC-M105S		21	M20XP2.5	30	80	142	35	45	25	5	118.7	146	113.2	81	130.2	211.2
RHC-M125S		25	M24XP3.0	35	110	168	44	51	26	5	128.7	168	123.2	91	130.2	221.2
RHC-M150S		31	M30XP3.5	45	110	196	45	56	26	5	134.7	199	129.2	97	130.2	227.2

單位: mm

技術資料 / Technical Data

型號 Model	尺寸 Dimension	活塞行程 Piston stroke mm	活塞直徑 Piston Dia mm	活塞面積 Piston Area		拉桿 Draw Bar		容許最高迴轉速度 Max Speed min ⁻¹ (r.p.m)	最大工作壓力 Max Operation Pressure MPa(kgf/cm ²)	總流量 Total Leakage L/min	轉動慣量 Moment Of Inertia kg·m ²	淨重 Net Weight kg
				前推端 Push side cm ²	後拉端 Pull side cm ²	前推端 Push side kN(kgf)	後拉端 Pull side kN(kgf)					
RHC-M105S		20	105	81.4	75.5	30.3 (3090)	28 (2864)	6000	4 (40.8)	0.8	0.0145	7.2
RHC-M125S		25	125	117.5	109	43.7(4460)	40.5 (4138)	6000	4 (40.8)	0.8	0.0276	9.7
RHC-M150S		30	150	171.5	156.7	63.8 (6509)	58.3 (5949)	5500	4 (40.8)	0.8	0.0514	12.8

註1: 總流量: 壓力3.0MPa (30.6kgf/cm²)、油溫50°C
 註2: 於精密液壓迴轉缸注油端必須使用濾網密度10µm過濾網
 註3: 限用ISO VG 32或ISO VG 46消泡性循環油

Remark 1: Total leakage : Pressure 3.0MPa (30.6kgf/cm²) and oil temperature 50°C.
 Remark 2: Circulating oil filter's net density should be under 10µm.
 Remark 3: Use only ISO VG 32 or ISO VG 46 deforming circulating oil.

HJ 精密動力夾頭硬爪系列

Hard Jaws for strong chuck series



1. 採用具耐用性、高強度之高級合金鋼材。
 2. 經過材質硬化處理，具結構強化與增加耐磨耗性。
 3. 具有強力夾持效果防止工件鬆動打滑，並適用於夾持不平整毛胚料。
1. Made of high-grade alloy steel with durable and high strength.
 2. After hardening, it strengthens the structure and increases the wear resistant.
 3. Base on strong chucking feature, it can prevent the workpiece loosening skid and applicable in uneven workpiece chucking.

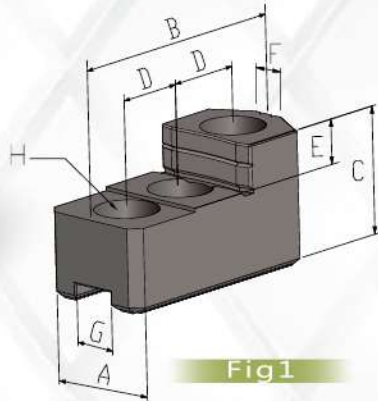

Fig1

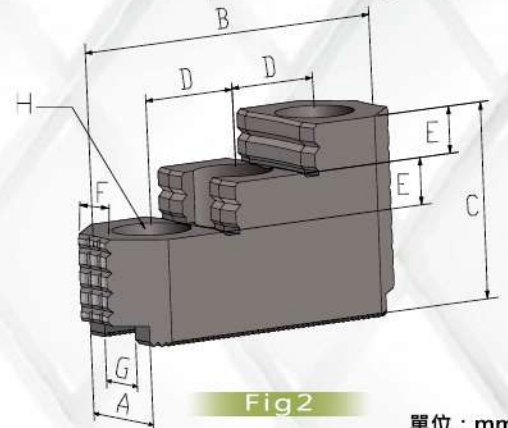

Fig2

單位：mm

外觀尺寸 / Dimensions

型號 Model	A	B	C	D	E	F	G	H	排齒 (Serration) (公制mm)	排齒(Serration) (英制inch)	適用夾頭型號 (Matching chuck)	參考圖 (Fig)
HJ05	23	53	27.5	14	10	6	10	M8	1.5x60°	英制規格 請來電諮詢 Inch size available upon request!	CH05	1
HJ06	31	67.5	39	20	12	12	12	M10	1.5x60°		CH06.CBH06.CNV06	1
HJ08	35	86	51	25	12	12	14	M12	1.5x60°		CH08.CBH08.CNV08	2
HJ10	40	99.5	54	30	13	15	16	M12	1.5x60°		CH10.CBH10.CNV10	2
HJ12	50	103	52	30	17	30	21	M16	1.5x60°		CH12.CBH12.CNV12	1
HJ15	62	149	86	43	20	40	22	M20	1.5x60°		CH15	2
HJ24	80	159.5	90	50	40	55	25	M20	1.5x60°		CH24.CNV21.CNV24	1

規格尺寸眾多，其他規格尺寸請來電洽詢

SJ 精密動力夾頭軟爪系列

Soft Jaws for strong chuck series

1. 採用高級合金鋼材質，具抗拉強度。
 2. 使用無硬化處理合金鋼材，具有高度可塑性及合金鋼材之穩定特性。
1. Made of high-grade alloy steel with tensile strength.
 2. Made of non-hardening alloy steel with high stability and adaptability jaws to fit the workpiece.

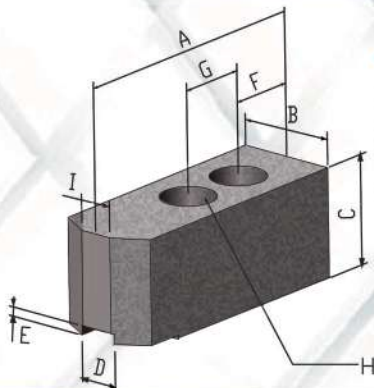

外觀尺寸 / Dimensions

單位：mm

型號 Model	A	B	C	D	E	F	G	H	I	排齒 (Serration) (公制mm)	排齒(Serration) (英制inch)	適用夾頭型號 (Matching chuck)	3J重量 Weight(kg)
SJ04	52	23	23	10	4	10	14	M8	4	1.5x60°	英制規格 請來電諮詢 Inch size available upon request!	CH05	0.4
SJ05	62	25	30	10	4	12	14	M8	5	1.5x60°		CH06	0.5
SJ06	73	31	36	12	5	12	20	M10	5	1.5x60°		CH08	0.8
SJ08	95	35	37	14	5	24	25	M12	12	1.5x60°		CH10	2.4
SJ10	110	40	42	16	5	30	30	M12	15	1.5x60°			3.6
SJ12	130	50	50	21	4	21	30	M16		1.5x60°			5.4
SJ15	165	62	62	25.5	5	26	43	M20		1.5x60°		7.3	



T 精密動力夾頭T型螺帽

T- NUT SERIES

1. 採用高級合金鋼材，具高抗拉強度。
2. 經過調質硬化處理，增強T型螺帽鋼性與韌性，以及使用壽命。

1. Made of high-grade alloy steel with high tensile strength.

2. The rigidity and toughness were enhanced after hardening treatment.

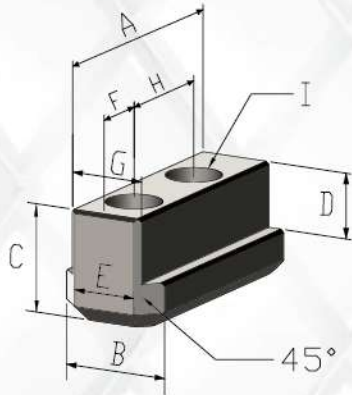

Fig1

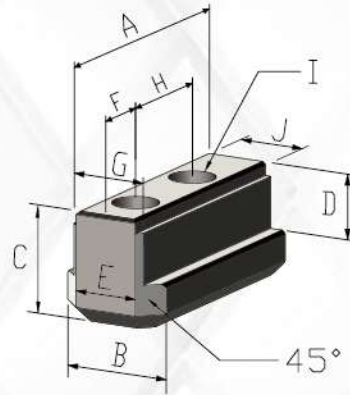

Fig2

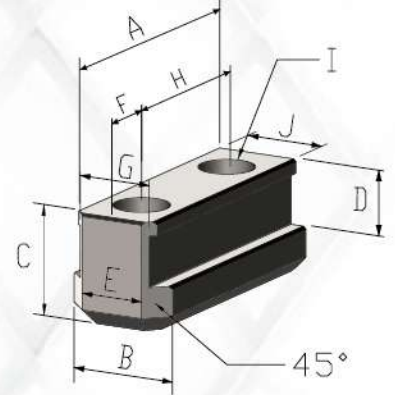

Fig3

外觀尺寸 / Dimensions

單位：mm

型號 Model	A	B	C	D	E	F	G	H	I	J	適用夾頭(Matching chuck)	參考圖(Fig)
TN04	26	14.5	18	12.5	5	6	10	14	M8			1
TN05	32	14.5	18	12.5	6	6	10	19	M8			1
TA05	26	14.5	15	9.5	5	6	10	14	M8		CH05	1
TC05	33.5	14.5	16	10.5	5	7	10	20	M8	12	CH05	3
TN06	36.5	17	22.5	15	8	7.5	12	20	M10		CNV06	1
TA06	36.5	17	18.5	11	8	8.25	12	20	M10		CH06	1
TB06	27	17	17.5	10	8	6.5	12	14	M8	10	CH06	2
TC06	41	17	18.5	11	8	8	12	25	M10	14	CH06	3
TN08	48	20	25.5	16	8	11	14	25	M12		CNV08	1
TA08	46.5	20	20.5	12	12	10.5	14	25	M12		CH08	1
TB08	36	20	20.5	12	12	8	14	20	M10	12	CH08	2
TC08	48	20	20.5	12	12	9	14	30	M12	16	CH08	3
TN10	55	22	25.5	16	8	11	16	30	M12		CNV10	1
TA10	51	22	21.5	13	11	11	16	30	M12		CH10	1
TB10	43	22	21.5	13	11	9	16	25	M12	14	CH10	2
TC10	48	22	21.5	13	11	9	16	30	M12	21	CH10	3
TA12	55.5	29.5	27.75	16.25	13	12	21	30	M16			1
TB12	48	29.5	28	17	13	9	21	30	M12	16		2
TA15	80	33.5	45.5	29	11	17	24	43	M20	22	CH15	2

註：
 TN系列:中實動力夾頭用T型塊
 TA系列:中空動力夾頭用T型塊
 TB系列:中空動力夾頭轉換軟爪用T型塊(大轉小)，如TB06為裝CH06夾頭，使用SJ05軟爪
 TC系列:中空動力夾頭轉換軟爪用T型塊(小轉大)，如TC06為裝CH06夾頭，使用SJ08軟爪
 TN series nut: The type of nut is used for the purpose of mounting on the non-through hole chuck series.
 TA series nut: The type of nut is used for the purpose of mounting on the through hole chuck series.
 TB series nuts: The TB series nut is used for the special purpose of converting the standard soft jaw to the smaller sizes one when mounting on the through hole chuck.
 (For example, TB06 T nut with SJ05 soft jaw to be mounted on CH06 chuck)
 TC series nuts: The TC nut is used for the special purpose of converting the standard soft jaw to the bigger sizes one when mounting on the through hole chuck.
 (For example, TC06 T nut with SJ08 soft jaw to be mounted on CH06 chuck)

規格尺寸眾多，其他規格尺寸請來電洽詢



精密動力夾頭專用連結板系列

MOUNTING ADAPTER SERIES

1. 採用高級合金鋼；具一定剛性與抗拉強度特性，使連結板具有精度之穩定性。
 1. Made of high-grade alloy steel with high tensile strength, the mounting adapter with stable precision.

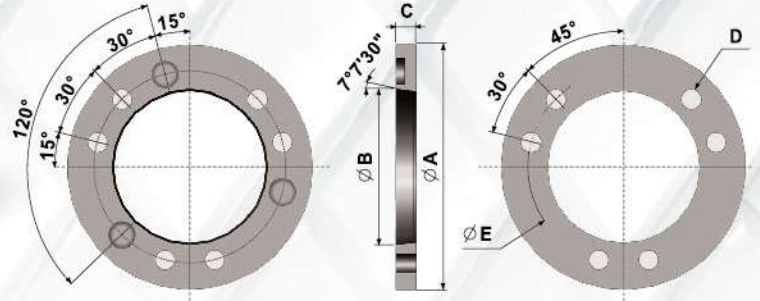

Fig1 適用於夾頭相對應標準大小主軸
 The chuck is directly mounted onto the spindle nose.

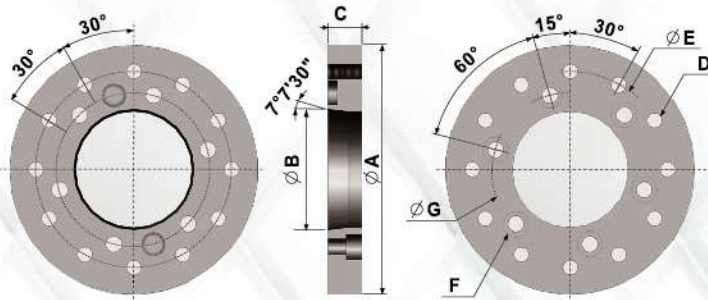

Fig2 適用於小主軸連結大夾頭
 Used when the spindle nose is smaller than the standard one on the chuck.

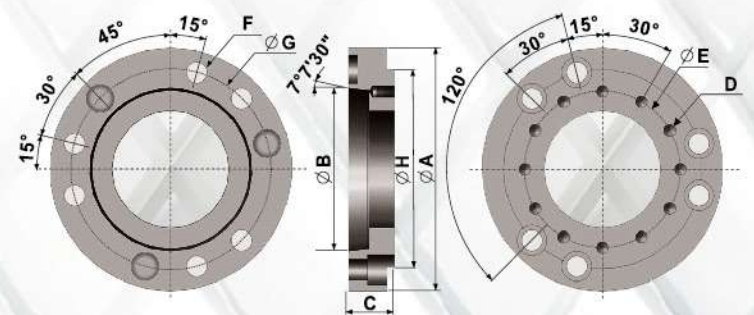

Fig3 適用於大主軸連結小夾頭
 Used when the spindle nose is bigger than the standard one on the chuck.

外觀尺寸 / Dimensions

單位：mm

夾頭轉接板編號 chuck adapters Id. No.	主軸端 Spindle nose	A mm	B mm	C mm	D mm	E mm	參考圖 (Fig)
CA05-A4	A4	110	63.5	15	M10	82.6	1
CA06-A5	A5	140	82.55	15	M10	104.8	1
CA08-A6	A6	170	106.36	17	M12	133.4	1
CA10-A8	A8	220	139.7	18	M16	171.4	1

夾頭轉接板編號 chuck adapters Id. No.	主軸端 Spindle nose	A mm	B mm	C mm	D mm	E mm	F mm	G mm	參考圖 (Fig)
CA06-A4	A4	140	63.5	20	M10	104.8	M10	82.6	2
CA08-A5	A5	170	82.55	23	M12	133.4	M10	104.8	2
CA10-A6	A6	220	106.36	25	M16	171.4	M12	133.4	2

夾頭轉接板編號 chuck adapters Id. No.	主軸端 Spindle nose	A mm	B mm	C mm	D mm	E mm	F mm	G mm	H mm	參考圖 (Fig)
CA06-A6	A6	165	106.36	35	M10	104.8	M12	133.4	140	3
CA08-A8	A8	208	139.7	40	M12	133.4	M16	171.4	170	3



DCB 精密迴轉缸專用集水盒系列

Coolant Collector

Hydraulic Cylinder Coolant Collector Series

特色 / Product Features



1. 材質: 鋁合金, 重量: 輕
 2. 集水、集油、集屑之功能, 附加固定鎖片, 可裝置檢知感應器
 3. 本身設有檢知感應器固定座
1. Material : aluminum alloy, Light weight.
 2. The function is collecting water, oil and dust, contain fixed locking plate and can installed the detect sensor.
 3. It has contained detection sensor's fixed holder.

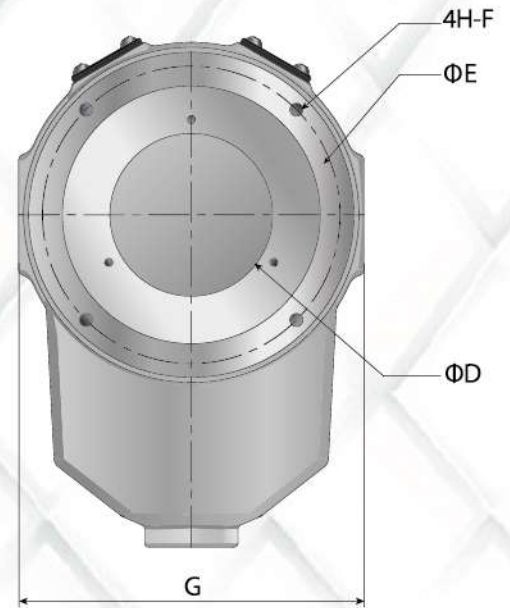
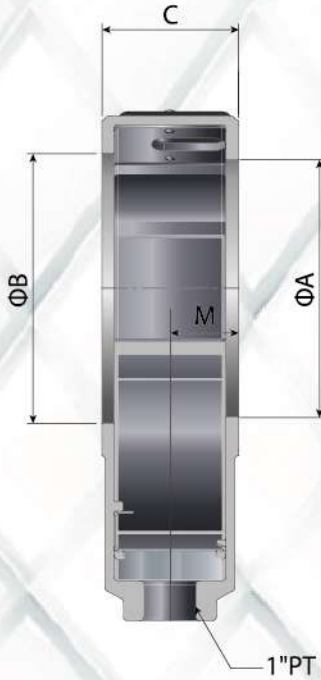
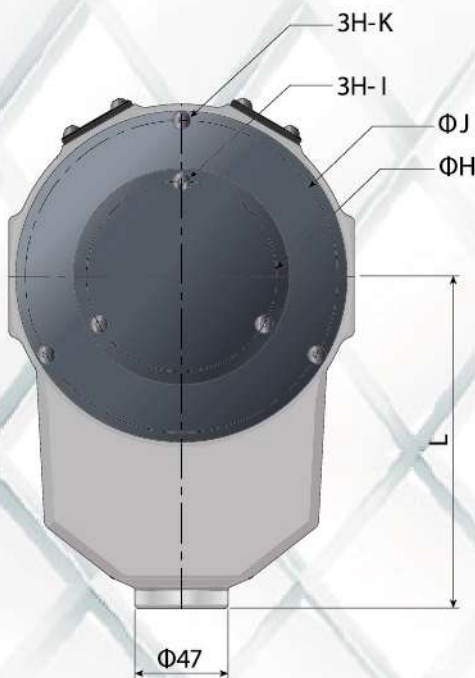
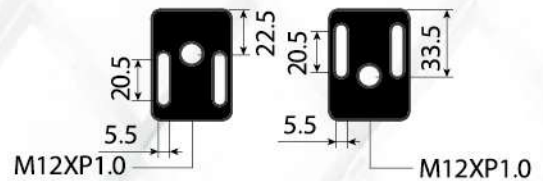
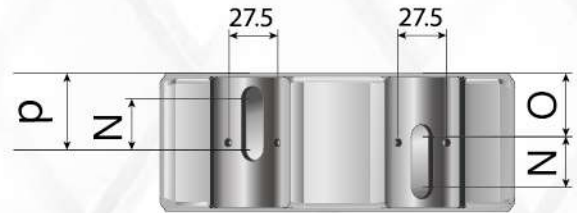

外觀尺寸 / Dimensions

型號 Model	尺寸 Dimension																	搭配迴轉油壓缸 Matching Cylinder
	A	B	C	D	E	F	G	H	I	J	K	L	M	N	O	P		
DCB-10	83	85	74	55	93	5.5	111.5	67	M4	96	M5	105	35	22	16.5	46	RHC-10系列	
DCB-12	90	105	64	55	100	5.5	145	67	M4	117	M5	135	30	20.5	27.2	33.2	RHC-12系列	
DCB-15	103	105	64	55	111	6.5	145	67	M4	117	M5	135	30	20.5	27.2	33.2	RHC-15系列	
DCB-18	133	134	73	82	143.5	6.5	174	96	M4	157.5	M5	167.5	35	25	31.7	37.7	RHC-18系列	
DCB-S13	90	105	64	55	103.5	5.5	145	67	M4	117	M5	135	30	20.5	27.2	33.2	RHC-S13系列	
DCB-S14	103	105	64	55	120	6.5	145	67	M4	117	M5	135	30	20.5	27.2	33.2	RHC-S14系列	
DCB-S17	130	134	73	82	150	6.5	174	96	M4	157.5	M5	167.5	35	25	31.7	37.7	RHC-S17系列	

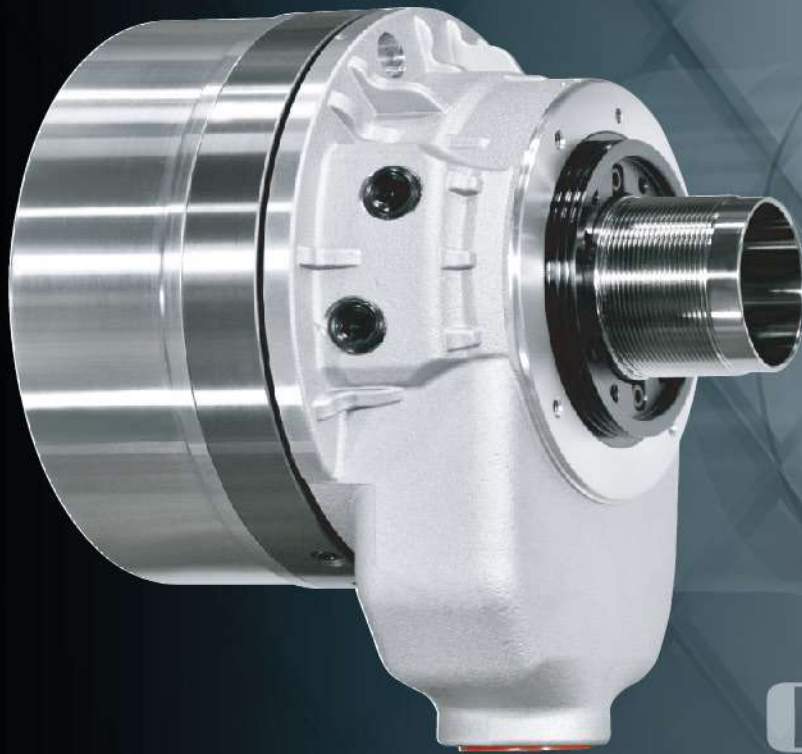

AUTO
CLAWS

AUTOCLAWS產品透過嚴格的品質控管，並通過ISO9001 2015 國際品質管理系統認證
且經德國TÜV Rheinland 產品實測認證，確保出產之產品皆為精品，AUTOCLAWS之精度與品質值得信賴
AUTOCLAWS產品均投保南山國際產品責任險，確實保障消費者的權益

專業製造銷售夾具系統

- 動力夾盤系列
- 高速迴轉液壓缸系列
- 夾具系統配件製造銷售
- 專業客製化夾具系統設計

AUTOCLAWS's product were produced by strictly quality control and passed ISO9001 2015 International quality management system certification. Also been tested and certificated by TUV Rheinland to ensure the product with high quality.

AUTOCLAWS's accuracy and quality are trustworthy.

AUTOCLAWS's products were all covered by Nanshan International product liability Insurance which truly protects the rights of consumers.

Professional manufacturing and sales fixture system

- Hydraulic chucks series
- Super high Speed hydraulic cylinders series
- Manufacturing and sales chucks system accessories
- Professional customized chucks system.



開合精密工業股份有限公司

542 南投縣草屯鎮中正路1151號

No.1151, Zhongzheng Rd., Caotun Township,

Nantou County 542, Taiwan

Email : helix.chuck@msa.hinet.net

autoclaws.mail@gmail.com

Tel : +886-49-2310-860 Fax : +886-49-2310-850

WWW.AUTOCLAWS.COM

